

BOULONNERIE FIXATION VISSERIE

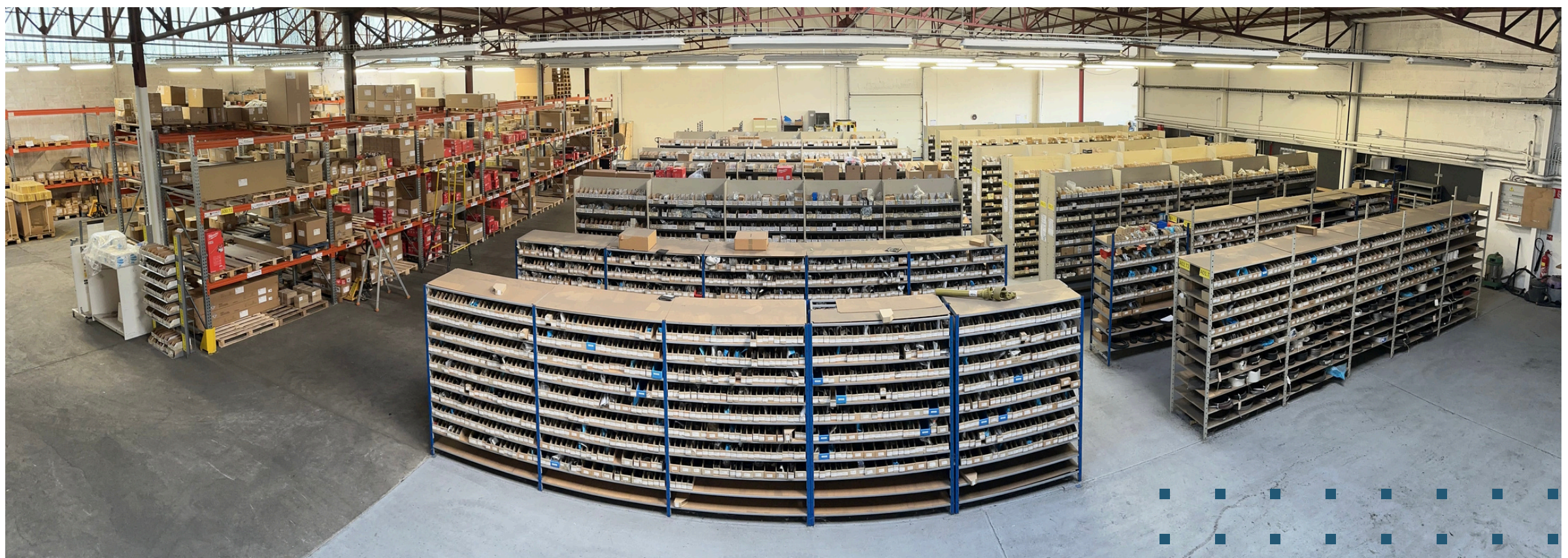

PLUS DE
25 000
RÉFÉRENCES



LE MANS - RENNES

WWW.SOAZIG.EU

Acier - Laiton - Polyamide

VIS À TÊTE HEXAGONALES MÉTRIQUES



DIN 931 ~ ISO 4014

4510

8.8 BR



DIN 931 ~ ISO 4014

4530

8.8 ZN



DIN 931 ~ ISO 4014

4520

10.9 BR



DIN 931 ~ ISO 4014

4522

10.9 ZN



DIN 931 ~ ISO 4014

4525

12.9 BR



DIN 933 ~ ISO 4017

4550

8.8 BR



DIN 933 ~ ISO 4017

4570

8.8 ZN

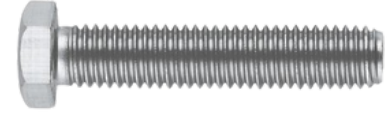

DIN 933 ~ ISO 4017

4572

8.8 GC

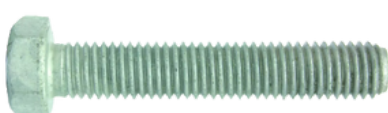

DIN 933 ~ ISO 4017

4560

10.9 BR



DIN 933 ~ ISO 4017

4562

10.9 ZN

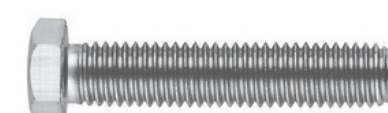

DIN 933 ~ ISO 4017

4526

12.9 BR



DIN 960 ~ ISO 8765

4630, pas fin

8.8 BR



DIN 960 ~ ISO 8765

4633, pas fin

8.8 ZN



DIN 960 ~ ISO 8765

4631, pas fin

10.9 BR



DIN 960 ~ ISO 8765

4632, pas fin

10.9 ZN



DIN 961 ~ ISO 8676

4670, pas fin

8.8 BR



DIN 961 ~ ISO 8676

4673, pas fin

8.8 ZN

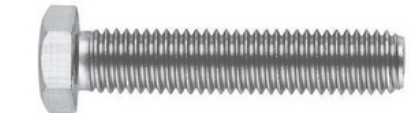

DIN 961 ~ ISO 8676

4671, pas fin

10.9 BR



DIN 961 ~ ISO 8676

4672, pas fin

10.9 ZN

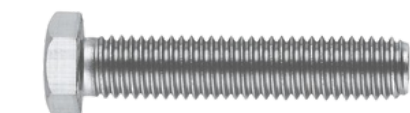

DIN 6921 ~ ISO 1665

4590

8.8 BR



DIN 6921 ~ ISO 1665

4591

8.8 ZN



DIN 933 ~ ISO 4017

4580

LA



DIN 933 ~ ISO 4017

8950

PL



VIS SIX PANS CREUX



DIN 912 F.T. ~ ISO 4762

4841

8.8 ZN



DIN 912 F.P. ~ ISO 4762

4825

10.9 BR



DIN 912 ~ ISO 4762

4830 / 4822, pas fin

12.9 BR



DIN 7984

4800

8.8 BR



DIN 7984

4800 ... ZN

8.8 ZN



ISO 7379

4831

8.8 BR



ISO 7380

4790

10.9 BR



ISO 7380

4835

10.9 ZN

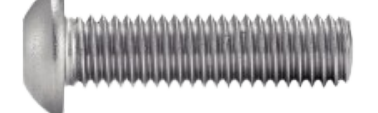

ISO 7380

4791, embase

10.9 BR



ISO 7380

4836, embase

10.9 ZN



ISO 7380 X

4837

10.9 ZN



DIN 7991 F.P. ~ ISO 10642

4890

10.9 BR



DIN 7991 F.P. ~ ISO 10642

4810, existe en filetage total

10.9 ZN



DIN 7991 F.T. ~ ISO 10642

4891

10.9 BR



Acier - Laiton - Polyamide

TIGES FILETÉES



DIN 975

4100, 4070 = Lg 2 M

4.6 BR



DIN 975

4180, 4182 = Lg 2 M et 3 M à préciser

4.6 ZN



DIN 975

4125

8.8 BR



DIN 975

4185

8.8 ZN



DIN 975

4119

10.9 BR



DIN 975

4112

12.9 BR



DIN 975

4110

LA



DIN 975

4090

PL



DIN 975

4120, pas fin

4.6 BR



DIN 975

4122, pas fin

12.9 BR



DIN 103

4170, trapézoïdal

4.6 BR



DIN 975

4080, pas à gauche

4.6 BR



VIS MÉTAUX



DIN 963 ~ ISO 2009

4390

4.6 ZN



DIN 963 ~ ISO 2009

4300

LA



DIN 963 ~ ISO 2009

8965

PL



DIN 964

4340

4.6 ZN

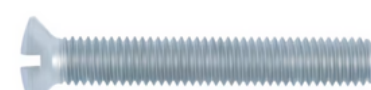

DIN 964

4301

LA



DIN 964

8970

PL



DIN 84 ~ ISO 1207

4350

4.6 ZN



DIN 84 ~ ISO 1207

4310

LA



DIN 84 ~ ISO 1207

8980 / 8981

PL



DIN 966

4341

4.6 ZN



DIN 965 ~ ISO 7046

4311

4.6 ZN



DIN 7985 ~ ISO 7045

4320

4.6 ZN

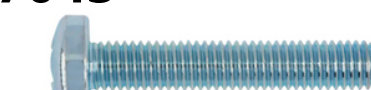

DIN 7985 ~ ISO 7045

4322, Empreinte Torx

4.6 ZN

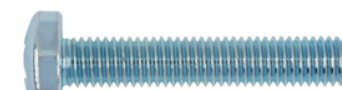

NFE 25129

4215

4.6 ZN



DIN 316

4370

4.6 ZN



DIN 916 ~ ISO 4029

4850 / 4851

14.9 BR ZN



DIN 913 ~ ISO 4026

4860 / 4861

14.9 BR ZN



DIN 914

4870

14.9 BR



DIN 915

4880

14.9 BR



Revêtement

BR	BRUT NOIR	ZN	ZINGUÉE
GC	GALVA À CHAUD		

Qualité

4.6	8.8
10.9	12.9
HV 300	

Matériaux

LA	LAITON	PL	POLYAMIDE	AL	ALU
A2	INOX A2	A4	INOX A4		

ÉCROUS



DIN 934 ~ ISO 4032

5100 / 5320 pas à gauche

8,8 BR Existe pas fin



DIN 934 ~ ISO 4032

5170

8,8 ZN Existe pas fin



DIN 934 ~ ISO 4032

5120

10,9 BR Existe pas fin



DIN 934 ~ ISO 4032

5121

10,9 ZN



DIN 934 ~ ISO 4032

5124

12,9 BR



DIN 934 ~ ISO 4032

5000, 8930

LA PL



DIN 934 ~ ISO 4032

5172

GC



DIN 439 B

5110 / 5321 pas à gauche

8,8 BR Existe pas fin



DIN 439 B

5180

8,8 ZN Existe pas fin



DIN 439 B

5002

LA



ISO 4033

5190

8,8 BR



ISO 4033

5122

10,9 BR Existe pas fin



ISO 4033

5010

LA



DIN 929

5001

8,8 BR



DIN 929

5390

8,8 BR



DIN 6334

4190

8,8 ZN



DIN 929

5470, pas trapézoïdal

8,8 BR Cylindrique Hexagonal Carré



DIN 980V

5230

8,8 ZN



DIN 6923 ~ ISO 1661

5150

8,8 ZN



DIN 6923 ~ ISO 1661

5151

10,9 BR



DIN 6926

5211

8,8 ZN



DIN 985 ~ ISO 10511

5210

8,8 ZN Existe pas fin



DIN 985 ~ ISO 10511

5213

10,9 ZN Existe pas fin



DIN 982 ~ ISO 7040

5250

8,8 ZN



NFE 25412

5255

8,8 ZN



DIN 935-1 ~ ISO 7035

5131, pas fin

8,8 BR



DIN 935-1 ~ ISO 7035

5130

8,8 BR



DIN 557

5303

8,8 ZN



DIN 1587

5140

8,8 ZN



DIN 1587

5030 / 8900

LA PL

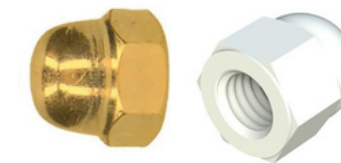

DIN 7967

5380

8,8 ZN



DIN 6923 ~ DIN 1661

5240

8,8 ZN



DIN 6923 ~ DIN 1661

5150

8,8 ZN



ÉCROU À AILETTES

5450

ZN



RONDELLES



NFE 25513

5600

BR M



NFE 25513

5610

ZN M



NFE 25513

8940

PL M



DIN 125

5614

GC M



NFE 25513

5601

BR Z



NFE 25513

5611

ZN Z



Acier - Laiton - Polyamide

AUTRES PRODUITS

NFE 25513
5505

LA Z



DIN 127 B
5770

ZN



NFE 22513
5602 / 5603

BR L LL



DIN 93
5940

ZN



NFE 25513
5612 / 5613

ZN L LL



DIN 463
5950

ZN



DIN 6340
5633

BR



NFE 27626
5670

ZN



DIN 7349
5631

ZN



DIN 6798 A
5730

ZN



DIN 6916
5640

BR 10 HV 300



DIN 6798 JZ
5720

ZN



NFE 25511
5660

ZN Z M L



NFE 25512
5750

ZN



TYPE SCHNORR
5690

BR



RONDELLE ATTELAGE
5632

BR D. 17 à 120 mm
Ep. 1,2 et 3 mm



TYPE SCHNORR
5693

ZN



DIN 988, CALAGE
5800

BR



NORD LOCK
5815

ZN

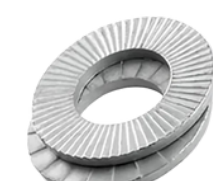

DIN 2093, RESSORT
5920

BR



NORD LOCK
5817

ZN L

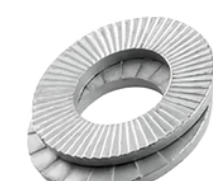

DIN 137 A, ONDUFLEX
5900

BR



NORD LOCK
5822

ZN X

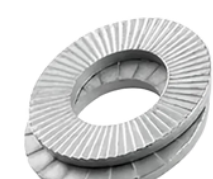

DIN 137 B, ONDUFLEX
5910

BR



NFE 25515
5790

BR



CONIQUE
5680

ACIER Assemblée en 3 ou 4 éléments



NFE 25515
5785

ZN



Taille

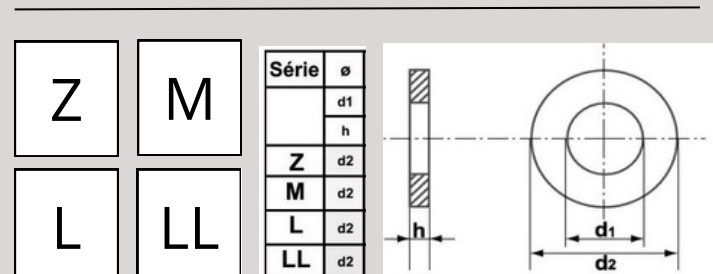

NFE 27487
7701

ZN



GOUPILLE CLIPS
7720

ZN



GOUPILLE CLIPS TUBE
7721

ZN



DIN 11024
7730

ZN



GOUPILLE BETA
7790

ZN



ISO 8752
7750

BR



DIN 7343 ~ ISO 8750
7753 / 7754

BR ZN



DIN 1B
7760

BR



DIN 6325 ~ ISO 8734
7762

BR



DIN 7979
7765

BR



DIN 1471
7770

BR



DIN 472
6410

BR



DIN 471
6400

BR



SERTISSAGE



ÉCROU À SERTIR BORGNE

7445 23310...

ZN Tête fraisée
Fût lisse borgne



ÉCROUS À SERTIR CYLINDRIQUE

7446 23300...

AL Tête plate
Fût lisse ouvert



ÉCROU À SERTIR CYLINDRIQUE

7446 23301...

ZN Tête plate
Fût lisse ouvert



ÉCROU À SERTIR CYLINDRIQUE

BOL23310...

AL Tête fraisée
Fût lisse ouvert



ÉCROU À SERTIR CYLINDRIQUE

BOL23311...

ZN Tête fraisée
Fût lisse ouvert



ÉCROU À SERTIR CYLINDRIQUE

BOL23317...

ZN Tête fraisée
Fût moleté ouvert



ÉCROU À SERTIR CYLINDRIQUE

BOL34301...

ZN Pour trous en côtes pouciques
Tête fine, filetage métrique
Fût lisse ouvert



ÉCROU À SERTIR CYLINDRIQUE

BOL34367...

ZN Tête fine
Fût moleté ouvert



ÉCROU À SERTIR HEXAGONAL

BOL23341...

ZN Tête plate
Fût hexagonal ouvert

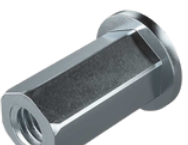

ÉCROU À SERTIR BORGNE

BOL23351...

ZN Tête plate
Fût hexagonal borgne



ÉCROU À SERTIR HEXAGONAL

BOL34321...

ZN Pour trous en côtes pouciques
Tête fine, filetage métrique
Fût semi-hexagonal ouvert



ÉCROU À SERTIR HEXAGONAL

BOL34341...

ZN Tête fine
Fût hexagonal ouvert



ÉCROU À SERTIR BORGNE

BOL34351...

ZN Tête fine
Fût hexagonal borgne



ÉCROU À SERTIR HEXAGONAL

BOL34391...

ZN Tête extra-fine
Fût hexagonal ouvert



ÉCROU À SERTIR HEXAGONAL

BOL23341...

ZN Tête plate
Fût semi-hexagonal ouvert



ÉCROU À SERTIR CYLINDRIQUE

BOL66830...

ZN Tête plate
Fût lisse ouvert fendu



ÉCROU À SERTIR HEXAGONAL

BOL66870...

ZN Tête plate
Fût lisse ouvert fendu
Plage de sertissage large



DIN 7337 ~ ISO 15978

7337

AL



DIN 7337 ~ ISO 15978

7342

AL



NFE 25-701

7339



Les produits de ce feuillet
sont disponibles sur notre
eshop



Machines de pose sur demande



Sertisseuse hydro-pneumatique
pour écrous à sertir M4 à M8

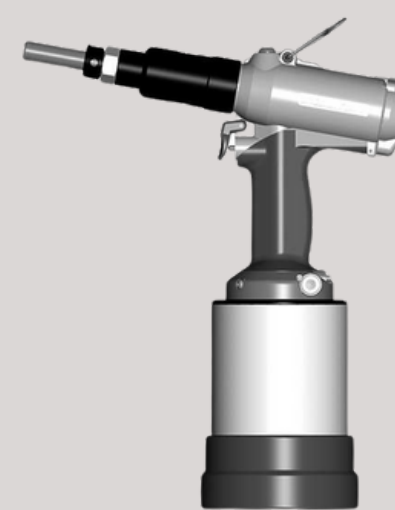

Sertisseuse pneumatique
pour écrous à sertir M4 à M10



Sertisseuse pneumatique
pour écrous à sertir M8 à M16



Riveteuse sur batterie pour rivets
4 à 6.4 et rivets de structure



Riveteuse pneumatique
pour rivets 4 à 6.4

VIS À TÊTE HEXAGONALES EN POUCES



ANSI B18-3

4720

8.8 BR UNC



ANSI B18-3

4710

8.8 BR UNF



ANSI B18-3

4952 / 4962

A2 A4 UNC



VIS SIX PANS CREUX EN POUCES



ANSI B18-3

4730

12.9 BR UNC



ANSI B18-3

4740

12.9 BR UNF



ANSI B18-3

4750

10.9 BR UNC



ANSI B18-3

4760

10.9 BR UNF



ANSI B18-3

4796

10.9 BR UNC



ANSI B18-3

4795

10.9 BR UNF



ANSI B18-3

4781, bout cuvette

14.9 BR UNC



ANSI B18-3

4783, bout cuvette

14.9 BR UNF



ANSI B18-3

4782, bout plat

14.9 BR UNC



ÉCROUS EN POUCES



ANSI B182.2

5300

8.8 BR UNC



ANSI B182.2

5301

8.8 ZN UNC



ANSI B182.2

5309

12.9 BR UNC



ANSI B182.2

5310

8.8 BR UNF



ANSI B182.2

5311

8.8 ZN UNF



5342

10.9 ZN UNF



ANSI B18.16.6

5330

8.8 ZN UNC



ANSI B18.16.6

5340

8.8 ZN UNF



ANSI B18.16.6

5350

A2 UNC



TIGES FILETÉES EN POUCES



DIN 975

4130

4.6 BR UNC



DIN 975

4150

4.6 BR UNF



DIN 975

4142

A2 UNC



AUTRES PRODUITS EN POUCES



FILETS RAPPORTÉS

6739 41300...

A2 UNC



FILETS RAPPORTÉS

6739 41320...

A2 UNC



SERTISSAGE

Pour les logements en côtes pouceuses, filetage métrique



ÉCROU À SERTIR HEXAGONAL

BOL34321...

ZN Tête fine, filetage métrique Fût semi-hexagonal ouvert



ÉCROU À SERTIR CYLINDRIQUE

BOL34301...

ZN Tête fine, filetage métrique Fût lisse ouvert

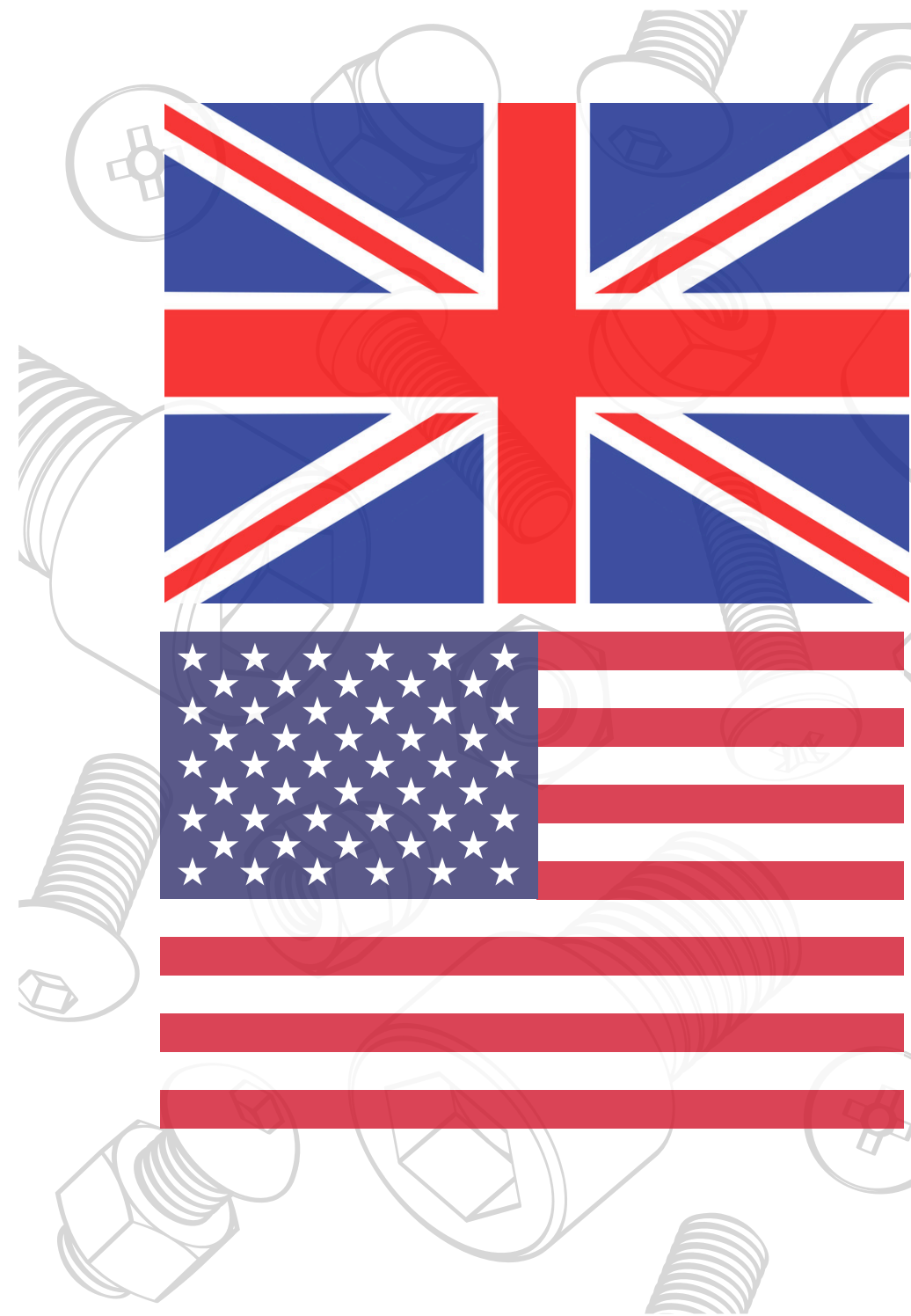

VIS À TÊTE HEXAGONALES MÉTRIQUES INOX



DIN 931
4950 / 4951

A2 A4



DIN 933
4960 / 4961

A2 A4

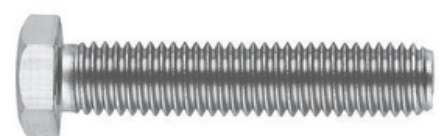

VIS SIX PANS CREUX INOX



DIN 912
4940 / 4941

A2 A4



DIN 912
4940 / 4941

A2 A4



DIN 7984
4943

A2



ISO 7379
4832

A2



ISO 7380-1
4942 / 4948

A2 A4



ISO 7380-2
4944

A2



DIN 7991
4990 / 4991

A2 A4



TIGES FILETÉES INOX



ISO 975
4140 / 4141

A2 A4



ISO 975
4082, pas à gauche

A2



ISO 975
4071 Lg 2 M

A2



VIS MÉTAUX INOX



DIN 963 ~ ISO 2009
4900 / 4901

A2 A4



DIN 964
4920 / 4921

A2 A4

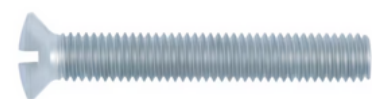

DIN 84 ~ ISO 1207
4910 / 4911

A2 A4



DIN 965 ~ ISO 7046
4914 / 4924

A2 A4



DIN 7985 ~ ISO 7045
4913 / 4923

A2 A4

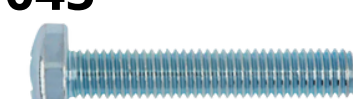

DIN 7985 ~ ISO 7045
4927, empreinte torx

A4



NFE 25129
4980 / 4981

A2 A4



DIN 316
4375

A2



DIN 916 ~ ISO 4029
4930

A2



DIN 913 ~ ISO 4026
4931 / 4932

A2 A4



DIN 914
4933

A2



DIN 915
4934

A2



ÉCROUS INOX



DIN 934
5039 / 5040

A2 A4



DIN 439B
5041 / 5042

A2 A4



DIN 929
5391

A2



DIN 912
4189

A2



DIN 6923
5092 / 5094

A2 A4



DIN 985 ~ ISO 10511
5050 / 5051

A2 A4



DIN 557
5305

A2

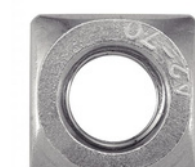

DIN 1587
5060 / 5061

A2 A4



DIN 986
5062

A2



DIN 7967
5381

A2



RONDELLES INOX



NFE 25513
5550 / 5551

A2 A4 M



NFE 25513
5554 / 5555

A2 A4 Z



NFE 25513

5552 / 5553



NFE 25513

5590 / 5591



DIN 7349

5592



NFE 25511

5661 / 5662



NORD LOCK

5819

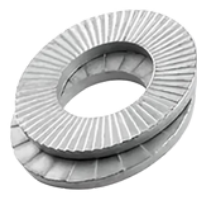

DIN 127 ~ NFE 25515

5570 / 5571



DIN 6798 A

5580 / 5581



DIN 6798 JZ

5582



TYPE SCHNORR

5692

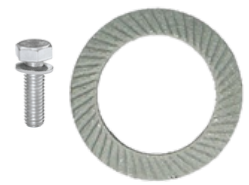

AUTRES PRODUITS INOX

DIN 94

7740



DIN 11024

7731

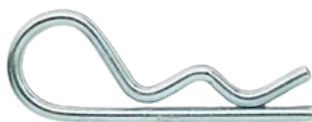

ISO 8752

7751

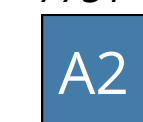

DIN 7343 ~ ISO 8750

7755

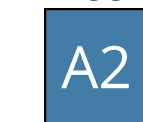

DIN 6325 ~ ISO 8734

7763



DIN 7979

7766

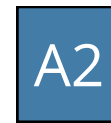

FILETS RAPPORTÉS

6739 41300...



FILETS RAPPORTÉS

6740 41320...

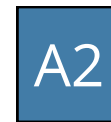

FILETS RAPPORTÉS

6742 51320...

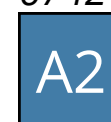

DIN 7337 ~ ISO 15978

7348

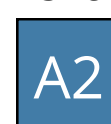

DIN 7337 ~ ISO 15978

7349



NFE 25-701

7350



DIN 472

6380



DIN 471

6370



SERTISSAGE



ÉCROU À SERTIR CYLINDRIQUES

7446 23306...



Tête plate
Fût moleté ouvert



ÉCROU À SERTIR CYLINDRIQUES

7446 23308...

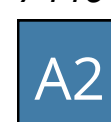

Tête plate
Fût lisse ouvert



ÉCROU À SERTIR CYLINDRIQUES

7446 23316...

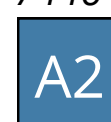

Tête fraisée
Fût moleté ouvert



ÉCROU À SERTIR CYLINDRIQUES

7446 23318...



Tête fraisée
Fût lisse ouvert



ÉCROU À SERTIR CYLINDRIQUES

7446 34308...



Tête fine
Fût lisse ouvert



ÉCROU À SERTIR CYLINDRIQUES

7446 34366...



Tête fine
Fût moleté ouvert



ÉCROU À SERTIR HEXAGONAL

7448 34348...



Tête fine
Fût semi-hexagonal ouvert



ÉCROU À SERTIR HEXAGONAL

7448 34398...



Tête extra-fine
Fût semi-hexagonal ouvert



INVIOLEBLE INOX



DIN 933 ~ ISO 4017

4965



ISO 7380

4968



ISO 7380

4945, empreinte Torx



DIN 7991 ~ ISO 10642

4967



DIN 7991 ~ ISO 10642

4971, empreinte Torx



SNAKE

4969



SNAKE

4970

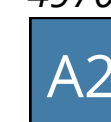

AUTOCASSANT

5035





SOAZIG
Fournitures industrielles et BTP



Groupe SOAZIG

OUEST FIXATION

38 Boulevard Pierre Lefauchaux
72100 LE MANS

Tel. +33 (0) 2 43 33 11 22
sas.ouestfixation@soazig.eu
www.soazig.eu

ROULIN

9 Impasse Irène Joliot Curie
35170 BRUZ

Tél. +33 (0)2 99 35 35 35
sas.roulin@soazig.eu
www.soazig.eu



À DÉCOUVRIR ÉGALEMENT

ANCRAGES LOURDS ET LÉGÉS

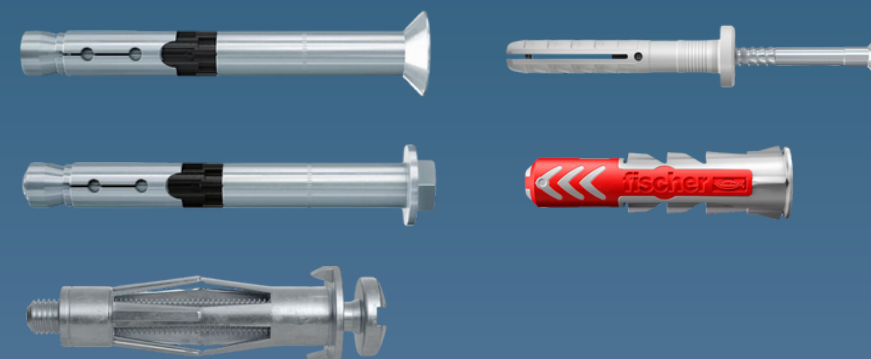

ÉLÉMENTS MÉCANIQUES



VIS BOIS & AUTOPERCEUSES



FABRICATION SPÉCIALE SUR DEMANDE

